



**ZEE Systems, Inc.**

**COMPONENT MAINTENANCE MANUAL**

**COMPONENT  
MAINTENANCE  
MANUAL**

**SZ 206**

**WITH**

**PARTS LIST**

**For**

**SCF206T-SERIES  
SCF206TC-SERIES  
SZ84-011-SERIES  
SZ84-913XX-SERIES**

**COMPRESSOR**

THIS MANUAL SUPERSEDES SERVICE INFORMATION LETTER SIL 206



**ZEE Systems, Inc.**

***COMPONENT MAINTENANCE MANUAL***

***RECORD OF REVISIONS***

| REVISION<br>NO: | ISSUE<br>DATE: | POSTED<br>DATE: | BY:               |
|-----------------|----------------|-----------------|-------------------|
| 1               | 10-20-02       | 10-20-02        | ZEE Systems, Inc. |
| 2               | 6-14-04        | 6-14-04         | ZEE Systems, Inc. |



**ZEE Systems, Inc.**

**COMPONENT MAINTENANCE MANUAL**

**LIST OF EFFECTIVE PAGES  
and  
TABLE OF CONTENTS**

| PAGE | TITLE                           | EFFECTIVE DATE/REV. |
|------|---------------------------------|---------------------|
| 1    | TITLE PAGE                      | REV.2               |
| 2    | Record of Revisions             | REV.2               |
| 3    | List of Effective Pages         | REV.2               |
| 4    | 1.0 INTRODUCTION                | REV.2               |
|      | 2.0 OPERATION                   | REV.2               |
|      | 3.0 SPECIAL TOOLS AND MATERIALS | REV.2               |
| 5    | 4.0 INSPECTION                  | REV.2               |
|      | 5.0 TOLERANCES                  | REV.2               |
|      | 6.0 SERVICE/REPAIR/REPLACEMENT  | REV.2               |
| 6    | 7.0 REASSEMBLY                  | REV.2               |
| 7    | 8.0 TEST PROCEDURES             | REV.2               |
| 8    | 9.0 TABLES AND FIGURES          | REV.2               |
| 9    | continued                       | REV.2               |
| 10   | continued                       | REV.2               |
| 11   | 10.0 PARTS LIST                 | REV.2               |

\* INITIAL RELEASE MAY 1996



## **ZEE Systems, Inc.**

# **COMPONENT MAINTENANCE MANUAL**

### **1.0 INTRODUCTION**

1.0.1 This manual includes instruction for the repair of the compressor used on the Motor-Compressor or Motor-Compressor-Condenser assemblies supplies as part of the ZEE Systems Vapor Cycle Air Conditioning Units.

### **2.0 OPERATION**

2.0.1 The ZEE Systems compressor is a single stage two piston compressor.

2.1 Rotation: The compressor can be operated in either clockwise or counter clockwise direction of rotation.

2.2 Mounting: The compressor can be mounted to operate in any position from horizontal left, horizontal right or upright. If the compressor is mounted horizontal the suction side should be on top.

2.3 Lubrication: A splash lubrication system provides more than adequate lubrication to the front and rear crankshaft bearings, connecting rods and cylinder walls. Positive pressure differential between the crankcase and the suction intake is utilized to provide lubrication to the front shaft seal. R-12 compressors use Mineral Oil and R-134a compressors use Castrol SW-100 a P.O.E. lubricant.

2.4 Speed: The Compressor is designed to operate between 500 and 6,000 RPM maximum (4,000 RPM continuous rating).

### **3.0 SPECIAL TOOLS AND MATERIALS**

3.1 The following tools and equipment are required to service or repair the compressor.

| ITEM  | SOURCE                 |
|---|------------------------|
| Torque Wrench (ft-lb)   | Commercially available |
| Leak Detector   | Commercially available |
| Seal Puller   | Commercially available |
| Dip Stick   | See FIG. 1             |
| Pressure Gauge 0-100 PSIG   | Commercially Available |
| (R-12) Mineral Oil  | Commercially available |
| (R-134a) Any synthetic Polyol Ester (P.O.E.) refrigerant oil with a ISO (viscosity) of 68 to 100<br>Lubrizol 2916<br>Nu-Calgon RL68S<br>CCI Retro-Fix II<br>Castrol SW-100 (R-134a) | Commercially Available |
| Degreaser (solvent)   | Commercially available |



## **ZEE Systems, Inc.**

# **COMPONENT MAINTENANCE MANUAL**

### **4.0 INSPECTION**

- 4.1 Check all components for cracks or other obvious defects.
- 4.2 Check cylinder walls for deep scoring which would affect compression.
- 4.3 With the head and valve plate removed rotate the shaft. Check for smooth rotation of the crankshaft. Check for any signs of binding of the piston in the cylinder and that the piston rises and falls smoothly.
- 4.4 Check that there is no end play in the crankshaft bearings. Check bearings for smooth rotation. Check that there is no dragging. The bearings are shrink fit should either bearing need replacement reject the compressor.
- 4.5 Check the pistons and connecting rods. rotate the shaft and check for smooth rotating. There should be no binding. Check the end cap bolts are tight, retighten if necessary.
- 4.5 Reject any compressor with any part that does not meet these inspections.

### **5.0 TOLERANCES**

- 5.1 See TABLE 1 for torque values.

### **6.0 SERVICE/REPAIR/REPLACEMENT**

#### **WARNING**

*THE AIR CONDITIONING SYSTEM IS UNDER PRESSURE. SERIOUS INJURY COULD OCCUR IF PROPER SAFEGUARDS ARE NOT TAKEN. WEAR PROPER SAFETY EQUIPMENT AND CLOTHING. R-12 (FREON) IS A CLASS I OZONE DEPLETING CHEMICAL (ODC). PROPER SAFEGUARDS MUST BE TAKEN TO RECOVER/RECYCLE AND OR DISPOSE OF ALL REFRIGERANTS.*

- 6.0.1 The compressor should be removed from the MCC Unit for any repairs. Refer to the MCC Maintenance Manual for more detailed instructions for compressor removal.
  - 6.0.1.1 If the compressor has back seating valves turn the valve stem all the way clockwise to isolate the compressor from the system. This will permit the removal of the compressor with out any refrigerant loss. Use a twelve point socket to remove the service valve from the cylinder head.
  - 6.0.1.2 If the compressor does not have back seating valves evacuate the system in accordance with acceptable and lawful E.P.A. refrigerant recovery practices.
- 6.0.2 All service and repairs should be performed in a clean, well lighted and well ventilated area. Protect the components from conditions which may cause deterioration or damage.
- 6.1 Shaft Seal: If a leak at the shaft seal is verified, replacement of the shaft seal is recommended.
  - 6.1.1 Remove the compressor from the assembly.



## **ZEE Systems, Inc.**

### **COMPONENT MAINTENANCE MANUAL**

6.1.2 Remove the pulley from the compressor. Take care not to damage the hard anodize coating on the pulley teeth. Using a small hand held torch or commercial heat gun heat up the aluminum pulley and lightly tap the pulley.

6.1.3 Remove the seal plate bolts and seal plate.

6.1.4 Remove the seal retainer with a seal puller. Note: If any tool other than a seal puller is used be careful not to damage the shaft or the machined surface on the front of the crankcase.

6.1.5 Discard the seal assembly, seal plate and O-Ring.

6.2 Cylinder Head and Valve Plate: The cylinder head is made of aluminum and care should be taken when removing it not to damage the seating surfaces.

6.2.1 Remove the remaining screws in the head and remove the valve plate from the head by prying or with a soft hammer tap under the ears which extend from the valve plate. Do Not hit or tap the head to separate the head and valve plate because damage to the head may result.

6.2.1 All gasket material adhering to the head, valve plate, or crankcase should be carefully removed in such a manner that the machines surfaces are not scratched or nicked.

6.3 Base Plate: Care should be taken when removing the base plate not to damage the seating surfaces.

6.3.1 Remove the base plate bolts.

6.3.2 Remove the base plate. If the base plate is stuck tap it lightly with a soft hammer.

6.3.3 Remove any gasket material from the base plate or the crankcase in such a manner such that the seating surfaces are not scratched or nicked.

## **7.0 REASSEMBLY**

7.1 Shaft Seal: Clean shaft seal cavity with a clean lint free cloth.

7.1.1 Dip the seal retainer in clean refrigerant oil.

7.1.2 Do not remove the carbon ring from the new seal retainer. However, be sure the notches in the outside edge of the carbon ring engage the dimpled lugs in the seal spring retainer.

7.1.3 Gently place the seal retainer (with the carbon ring in place) on to the nose of the shaft. Be sure the seal retainer is level.

7.1.4 Lubricate the new O-ring with compressor oil and place it in the groove of the seal plate.

7.1.5 Gently place the seal plate squarely on the face on the carbon. Gently apply thumb pressure to both sides of the steel plate and the push plate (and seal retainer) down all the way on the shaft.

7.1.6 Position the seal plate with uniform clearance around the shaft and install the six cap screws. Tighten cap screws in the sequence shown in FIG.2 Torque to 5-8 ft-lbs.



## **ZEE Systems, Inc.**

### ***COMPONENT MAINTENANCE MANUAL***

7.2 Cylinder Head and Valve Plate: Valve and valve plates are complete assemblies, no repair is permitted.

7.2.1 Apply a thin film of clean refrigeration oil on the area of the crankcase to be covered by the crankcase gasket. Place the cylinder gasket in position on the cylinder so the dowel pins in the crankcase go through the dowel pin holes in the cylinder gasket.

7.2.2 Apply a thin film of clean refrigeration oil to the top and bottom valve plate areas to be covered by gaskets. Place the valve plate in position on the cylinder gasket so the discharge valve

assemblies (i.e. the smaller diameter assemblies with the restrainer over the reed valve) are facing up and the locating dowel pins go through the dowel pin holes in the valve plate.

7.2.3 Place the head gasket, with the bead facing up, in position on the valve plate so the dowel pins go through the dowel pin holes in the gasket.

7.2.4 Apply a light film of clean refrigeration oil on the machined surface of the cylinder head which matches the head gasket. Place the head on the cylinder head gasket so the dowel pins go into the dowel pin holes in the head.

7.3 Base Plate: Apply a thin film of clean refrigeration oil to the new gasket and the sealing surface of the crankcase base plate.

7.3.1 Properly align the gasket on the crankcase.

7.3.2 Install the base plate and bolts. Tighten base plate bolts in the sequence shown in FIG. 2 to 10-16 ft-lbs torque.

7.4 After testing install the compressor to the MCC in accordance with instructions of the MCC Maintenance Manual. Install new O-rings under the service ports. Lubricate the O-rings with clean refrigeration oil prior to installation. Torque in accordance with TABLE 1.

## **8.0 TEST PROCEDURES**

8.1 Pressure Test: Install the pulley back on the compressor.

8.1.1 If the service ports have back seating valves, be sure the valves are open (in the back seat position). Connect the pressure gauge to the discharge port as shown in FIG. 3.

8.1.2 Turn the pulley by hand. Within 3 to 5 turns the compressor should develop a pressure of at least 15 PSIG. Slowly release the pressure.

8.2 Static Test FIG. 4: Cap the discharge port. Connect a refrigerant bottle (R-12 or R-134a) to the suction service port. Open the valve on the refrigerant bottle or. Using a leak detector check for leaks. No leaks are permissible. If the service ports have back seating valves, be sure the valves are open (in the back seat position).

8.2.1 Alternate Static Test FIG 4. Cap the discharge port. Connect a source of dry nitrogen to the suction port. Apply the dry nitrogen at pressure of 85 psig  $\pm$  5. Using a soap solution check for leaks. No leaks are permissible. If the service ports have back seating valves, be sure the valves are open (in the back seat position).



**ZEE Systems, Inc.**

**COMPONENT MAINTENANCE MANUAL**

**9.0 TABLES AND FIGURES**

9.1 Refer to the following TABLES for additional information.

9.1.1 Torque values.

| LOCATION                 | THREAD         | HEAD | FIELD TORQUE SPECS               |
|--------------------------|----------------|------|----------------------------------|
| Baseplate                | 1/4" - 20 UNC  | Hex  | 10-16 ft.-lb. (13.6-21.7 N-m)    |
| Rear Bearing Cover Plate | 1/4" - 20 UNC  | Flat | 10-16 ft.-lb. (13.6-21.7 N-m)    |
| Cylinder Head            | 5/16" - 18 UNC | Hex  | 17-25 ft.-lb. (23.0-33.9 N-m)    |
| Seal Plate               | 10-24 UNC      | Hex  | 5-8 ft.-lb. (6.8-10.8 N-m)       |
| Oil Fill Plug            | 3/8" - 24 UNF  | Hex  | 5-10 ft.-lb. (6.8-13.6 N-m min.) |
| Clutch Mounting Screw    | 1/4" - 20 UNC  | Hex  | 12-14 ft. lb. (10.8-19.0 N-m)    |
| Clutch Center Bolt       | 5/16" - 24 UNF | Hex  | 20-25 ft. lb. (27.1-33.9 N-m)    |
| Rotalock Valve           | 1" - 14 UNS    | Hex  | 35-40 ft. lb. (47.5-54.2 N-m)    |
| Tube 'O' Valve           | 1" 14 UNS      | Hex  | 35-40 ft.-lb. (47.5-54.2 N-m)    |
| Flange Valve             | 5/16" - 18 UNC | Torx | 17-25 ft.-lb. (23.0-33.9 N-m)    |
| Pressure Relief Valve    | 3/8" - 24 UNF  | Hex  | 5-10 ft.-lb. (6.8-13.6 N-m)      |

TABLE 1.

9.1.2 The TABLE below shows the crankcase oil charge in fluid ounces at various dip stick measurements for both horizontal and vertical mounts. The oil charge after the system is stabilized should be maintained with 6 fluid ounces minimum and 8 to 12 fluid ounces for best results.

|                        | Horizontal Mount   | Vertical Mount      |
|------------------------|--------------------|---------------------|
| 6 fl. oz.<br>(177 ml)  | 3/4"<br>(19 mm)    | 1"<br>(25 mm)       |
| 8 fl. oz.<br>(237 ml)  | 1"<br>(25 mm)      | 1-1/4"<br>(32 mm)   |
| 10 fl. oz.<br>(296 ml) | 1-3/16"<br>(30 mm) | 1-1/2"<br>(38 mm)   |
| 12 fl. oz.<br>(355 ml) | 1-7/16"<br>(37 mm) | 1-13/16"<br>(46 mm) |
| 14 fl. oz.<br>(414 ml) | 1-3/4"<br>(44 mm)  | 2-1/16"<br>(52 mm)  |

TABLE 2.





# ZEE Systems, Inc.

## COMPONENT MAINTENANCE MANUAL

9.2 Refer to the following FIGURES for additional information.

9.2.1 Dip Stick.

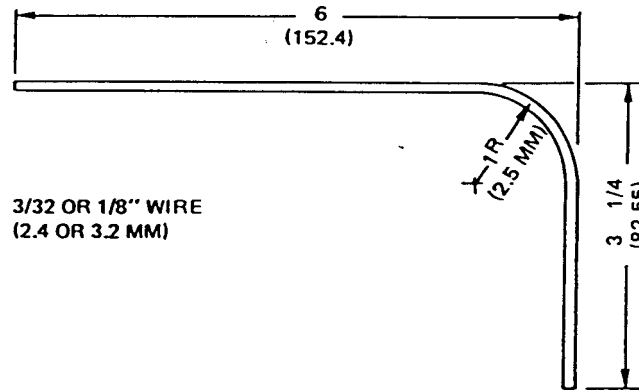

FIGURE 1.

9.2.2 Torque Sequence

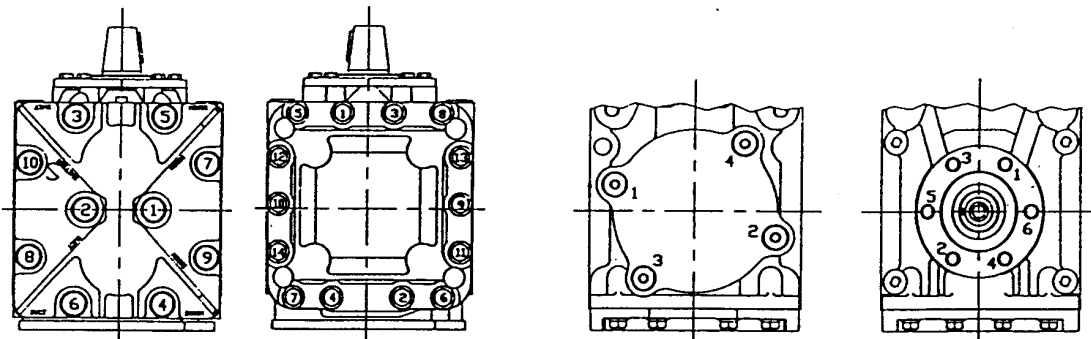

FIGURE 2.

9.2.3 Test Set Up.

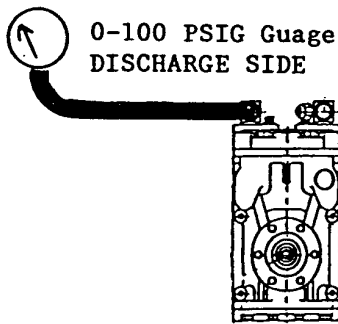

FIGURE 3

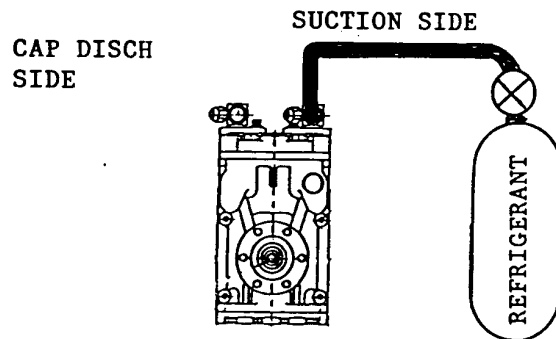

FIGURE 4



# ZEE Systems, Inc.

## COMPONENT MAINTENANCE MANUAL

### 9.2.4 Parts Breakdown.

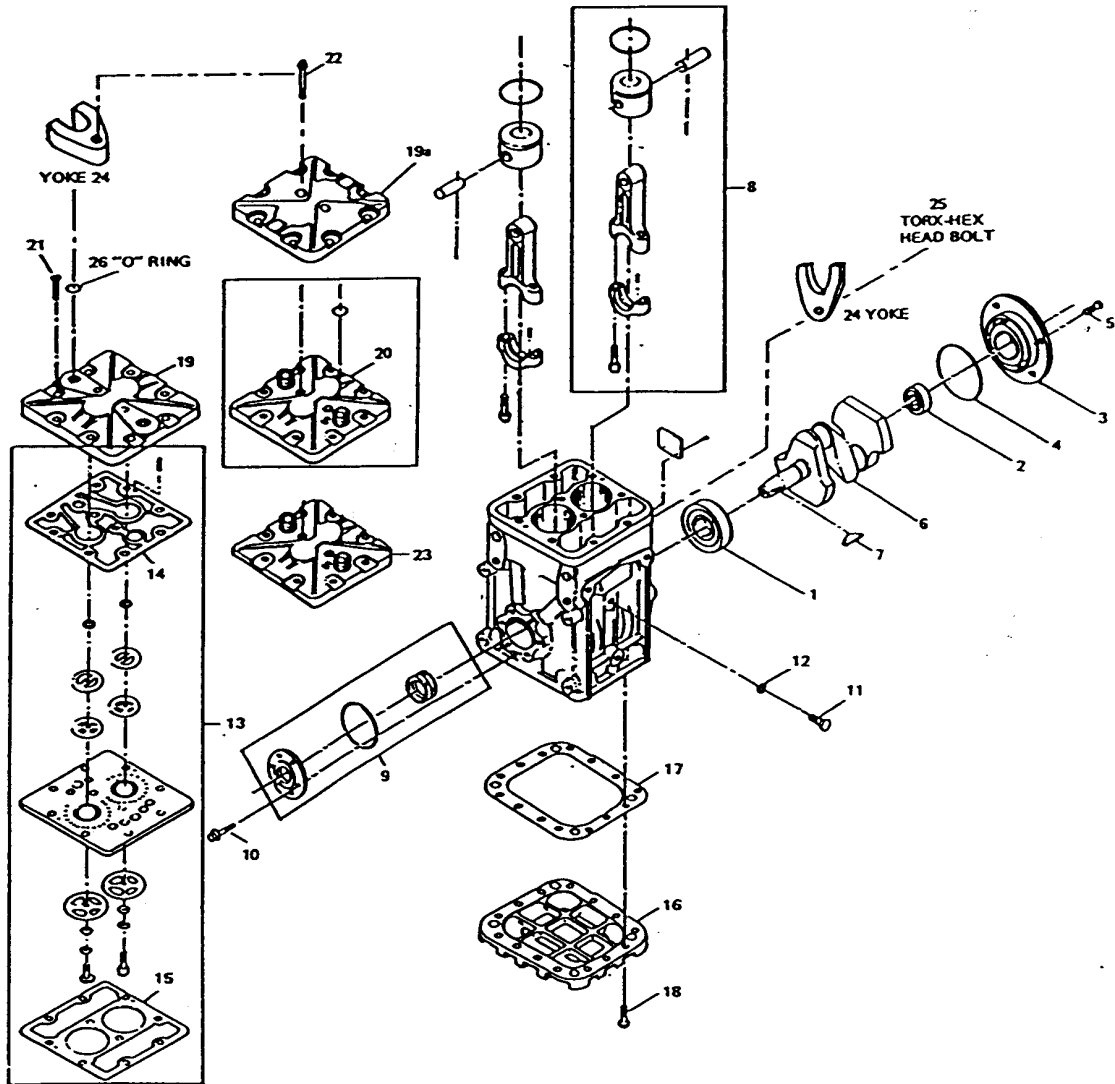

FIGURE 5.



## ZEE Systems, Inc.

### COMPONENT MAINTENANCE MANUAL

#### 10.0 PARTS LIST

10.1 FIGURE 5 shows the parts breakdown of the compressor. Not all parts are procurable. Only those parts available are listed. Refer to the following Legend.

NHA - Next Higher Assembly.

NS - Not Shown.

NP - Not Procurable as a separate item, refer to the NHA.

\* - Included in Seal Kit P/N: 488-20797.

#### PARTS LIST

| FIG. 5<br>- ITEM | PART NUMBER       | DESCRIPTION           | USAGE<br>CODE | QTY PER<br>ASSY. |
|------------------|-------------------|-----------------------|---------------|------------------|
| 5-               | SCF206T-21905     | Compressor R-12       | A             |                  |
|                  | SCF206TC-21905    | Compressor R-12       | B             |                  |
|                  | SZ84-011-1        | Compressor R-134      | C             |                  |
|                  | SZ84-913XX-SERIES | Compressor R-134      | D             |                  |
| -4               | 028-07145         | O-Ring                |               | 1                |
| -5               | 021-14634         | Screw                 |               | 4                |
| -7               | 029-09888         | Key                   |               | 1                |
| -9               | 488-25274         | Shaft Seal Kit        |               | 1                |
| -10              | 021-14136         | Cap Screw             |               | 6                |
| -11              | 021-12373         | Oil Fill Plug         |               | 1                |
| -12              | MS28775-012       | O-Ring                |               | 1                |
| -13              | 488-30321         | Valve Plate Assy      |               | 1                |
| -14              | *NP               |                       |               |                  |
| -15              | *NP               |                       |               |                  |
| -16              | 012-05521         | Base Plate            |               | 1                |
| -17              | *NP               |                       |               |                  |
| -18              | 021-12662         | Bolt                  |               | 14               |
| -19              | 088-20190         | Flanged Cylinder Head |               | 1                |
| -21              | 021-12578         | Bolt                  |               | 8                |
| -22              | 021-15002         | Bolt                  |               | 2                |
| -26              | 028-21695         | O-Ring                |               | 2                |
| NS               | 488-20797         | Seal Kit              |               | 1                |

Alternate: 488-20324

\* Included in Seal Kit