



ZEE SYSTEMS, Inc.
AIRCRAFT AIR CONDITIONING and
HEATING SYSTEMS

Z12-036 COMPONENT MAINTENANCE MANUAL

***Component
Maintenance
Manual***

with

Illustrated Parts List

for

Z12-036-SERIES

Relay Panel Assembly



ZEE SYSTEMS, Inc.
AIRCRAFT AIR CONDITIONING and
HEATING SYSTEMS

Z12-036 COMPONENT MAINTENANCE MANUAL

List of Effective Pages and Table of Contents

PAGE	TITLE	EFFECTIVE DATE / REV
1	COVER PAGE	*
2	RECORD OF REVISIONS	*
3	LIST OF EFFECTIVE PAGES	*
4	1.0 INTRODUCTION	*
	2.0 SPECIAL TOOLS AND EQUIPMENT	
	3.0 REPAIR AND REPLACEMENT OF COMPONENTS	*
5	continued	*
6	4.0 SERVICE SCHEDULES	*
	5.0 TOLERANCES	*
7	6.0 TROUBLE SHOOTING	*
8	continued	*
9	7.0 ILLUSTRATED PARTS LIST	*
10	continued	*
11	FIGURE 1	*
12	FIGURE 2	*

* INITIAL RELEASE 5-4-01



Z12-036 COMPONENT MAINTENANCE MANUAL

1.0 INTRODUCTION

1.1 This Component Maintenance Manual provides information on the maintenance, maintenance schedules and repair and replacement of parts.

1.2 Refer to the Illustrated Parts List (IPL) in Section 7 when using this manual or ordering replacement parts. Parts are identified in parenthesis (FIG-ITEM NO.).

1.3 This Relay Panel is part of a vapor cycle air conditioning system. The Relay Panel controls the operations of the Motor-Compressor-Condenser Assembly, the Evaporator-Heater Assemblies and the load shedding of the systems under certain circumstances.

1.3.1 The refrigeration charge of the vapor cycle components do not have to be disturbed or serviced when performing maintenance of the Relay Panel.

2.0 SPECIAL TOOLS AND EQUIPMENT

2.1 TOOLS: The following special tools are required to perform the maintenance described in this manual.

ITEM	SOURCE
Digital Multi-Meter (DMM)	Commercially Available

2.2 MATERIALS: There are no special materials required to perform maintenance described in this manual. Refer to Section 7 for part numbers when ordering replacement parts.

3.0 REPAIR AND REPLACEMENT OF COMPONENTS

CAUTION
BEFORE PERFORMING ANY SERVICE OF ELECTRICAL COMPONENTS MAKE SURE MAIN AIRCRAFT ELECTRICAL POWER IS DISABLED.

NOTE
SERVICE DESCRIBED IN THIS MANUAL SHOULD ONLY BE PERFORMED BY QUALIFIED PERSONNEL.

3.0.1 Refer to Addison Express installation drawings for instructions to access the Relay Panel. Remove covers/panels as necessary.

3.0.2 It is not necessary to remove the Relay Panel from the aircraft to perform trouble shooting and parts replacement on the Relay Panel.

3.0.3 Refer to AC43-13-1B for further guidance when performing maintenance on electrical systems and components.



Z12-036 COMPONENT MAINTENANCE MANUAL

3.0.4 There is no field repair of components. Defective components must be replaced.

3.1 RELAY (1-31)(K1, K3, K5, K6)

3.1.1 REMOVAL: Remove diode (1-34) and note the direction. Loosen electrical connections and remove hardware. Remove attaching wires or buses. Save hardware to re-attach wires or buses. Remove attaching hardware. Discard the defective relay.

3.1.2 INSTALLATION: Install Diode across X1 and X2 in the same direction as removed. Attach Relay to Plate Assy (1-7, 1-41). Attach wires and busses. Refer to FIG. 2.

3.2 RELAY (1-27) (K2, K4, K7, K8)

3.2.1 REMOVAL: ***NOTE: If the replacement relay is procured from ZEE Systems, Inc. you do not need to unsolder the wires attached to the relay. The replacement relay will come with the correct wire lengths (marked) and ring terminals. When ordering specify K2, K4, K7, K8 for Z12-030 Relay Panel.*** To disconnect the wires from their termination loosen and remove the hardware that secures the wires. Loosen and remove the hardware (1-29, 1-17, 1-40). Save hardware to re-attach wires or buses. Discard the defective relay.

3.2.2 INSTALLATION: Attach Relay to Plate Assy (1-7, 1-41). Attach wires and busses. Refer to FIG. 2.

3.3 CURRENT LIMITER (1-26) (F1, F2)

3.3.1 REMOVAL: Loosen the hardware that secures the defective fuse to the fuse block (1-39). Discard the defective fuse.

3.3.2 INSTALLATION: Place new fuse in fuse block and tighten the hardware.

3.4 CURRENT LIMITER (1-25) (F3)

3.4.1 REMOVAL: Loosen the hardware that secures bus (1-3, 1-4) at relay K5 and K6 (1-31). Loosen the hardware that secures the defective fuse to the fuse block (1-39). Discard the defective fuse.

3.4.2 INSTALLATION: Place new fuse in fuse block and tighten the hardware that secures bus (1-3, 1-4) to relay K5 and K6. Tighten the hardware that secures the fuse to the fuse block (1-39).

3.5 FUSE (1-35, 1-36, 1-37, 1-38) (F4, F5, F6, F7, F8, F10)

3.5.1 REMOVAL: Pry the defective fuse from the holder (1-5, 1-6) clips. Discard the defective fuse. ***CAUTION: This fuse has a glass body. Use care when prying fuse from holder clip.***

3.5.2 INSTALLATION: Press the new fuse into the holder (1-5, 1-6) clips.



Z12-036 COMPONENT MAINTENANCE MANUAL

4.0 SERVICE SCHEDULES

4.1 MAINTENANCE SCHEDULE

ITEM DESCRIPTION	INSPECTION INTERVAL *	R&R/T.B.O. HRS
Relay K1, K2, K3, K4, K5, K6, K7, K8	ON CONDITION	ON CONDITION
FUSE F1, F2, F3, F4, F5, F6, F7, F8, F10	ON CONDITION	ON CONDITION
DIODE D1 12ea. SEE FIG. 2	ON CONDITION	ON CONDITION
DIODE D2 2ea SEE FIG. 2	ON CONDITION	ON CONDITION

5.0 TOLERANCES

5.1 TORQUE VALUES. Use standard torque values for bolts, nuts and screws.



Z12-036 COMPONENT MAINTENANCE MANUAL

6.0 TROUBLE SHOOTING

6.0.1 Only a qualified aircraft electrician should perform trouble shooting duties.

6.0.2 When trouble shooting always check the condition of the wires to and from the relay panel. Check the components that are controlled by the relay panel for proper operation. Check for proper grounds.

6.0.3 Check the Fuses and Current Limiters on the Relay Panel. A blown fuse or current limiter is result of higher than desired current. This may be an indication of another problem. Check for worn or frayed wires, loose connections or other defective components.

6.0.4 These trouble shooting steps are for the relay panel only. Determine the function to be selected. Refer to FIG. 2. Isolate the component (s) that are part of the circuit selected.

6.0.5 The Relay Panel may be returned to an authorized ZEE Systems, Inc. repair facility for complete bench Functional Test in accordance with TP Z12-030.

TROUBLE	POSSIBLE CAUSE	REMEDY
6.1 A/C, GROUND selected. Nothing Happens.	K6 INOP	REPLACE
	F10 Blown	REPLACE
	K5 INOP	REPLACE
Motor-Compressor- Condenser INOP.	F3 Blown	REPLACE
	K5 INOP	REPLACE
FWD blowers INOP.	F5 Blown	REPLACE
	K2 INOP	REPLACE
AFT blower INOP.	F4 Blown	REPLACE
	K4 INOP	REPLACE
6.2 A/C, FLIGHT selected, GEN1 & GEN2 online. Nothing happens.	F10 Blown.	REPLACE
	K6 INOP	REPLACE
	F8 Blown	REPLACE
	K7 INOP	REPLACE
	K8 INOP	REPLACE
Motor-Compressor- Condenser INOP.	F3 Blown	REPLACE
	K5 INOP	REPLACE



Z12-036 COMPONENT MAINTENANCE MANUAL

TROUBLE	POSSIBLE CAUSE	REMEDY
FWD blowers INOP.	F5 Blown K2 INOP	REPLACE REPLACE
AFT blower INOP.	F4 Blown K4 INOP	REPLACE REPLACE
6.3 HEAT, GROUND selected. Nothing happens.	F10 Blown. K6 INOP F8 Blown	REPLACE REPLACE
FWD Heater Element INOP.	F1 Blown K1 INOP	REPLACE REPLACE
FWD blowers INOP.	F5 Blown K2 INOP	REPLACE REPLACE
AFT Heater Element INOP.	F2 Blown K3 INOP	REPLACE REPLACE
AFT blower INOP	F4 Blown K4 INOP	REPLACE REPLACE
6.4 HEAT, FLIGHT selected. GEN1 & GEN2 online. Nothing happens.	F10 Blown. K6 INOP F8 Blown K7 INOP K8 INOP	REPLACE REPLACE REPLACE REPLACE REPLACE
FWD Heater Element INOP.	F1 Blown K1 INOP	REPLACE REPLACE
FWD blowers INOP.	F5 Blown K2 INOP	REPLACE REPLACE
AFT Heater Element INOP.	F2 Blown K3 INOP	REPLACE REPLACE
AFT blower INOP	F4 Blown K4 INOP	REPLACE REPLACE



Z12-036 COMPONENT MAINTENANCE MANUAL

7.0 ILLUSTRATED PARTS LIST

7.1 EXPLANATION OF SYMBOLS:

ALT - The Part Number shown is an approved alternate, either part number may be used.

MOD "X" Refers to modification information of this part as applicable to this assembly.

NP - Not Procurable individually, see next higher assembly.

NS - Not Shown

OBS - Obsolete

USAGE/QTY - This identifies parts used on specific applications (not common to all units).

. - Part of higher assembly.

*/# - See explanation at end of parts list.

FIG-ITEM	PART NUMBER	NOMENCLATURE	QTY	USAGE CODE
	Z12-030-1	RELAY PANEL		A
	Z12-030-2	RELAY PANEL		B
1	-1	Z12-031-3	1	A,B
1	-2	Z12-031-15	1	A,B
1	-3	Z12-032-1	1	A,B
1	-4	Z12-032-2	1	A,B
1	-5	Z12-033-4	1	A,B
1	-6	Z12-033-4	1	A,B
1	-7	Z12-034-1	1	A
1	-8	Z12-301-1	1	A,B
1	-9	Z12-301-2	1	A,B
1	-10	Z12-400-1	4	A
1	-11	Z12-500-1	1	A
1	-12	AN364-440A	4	A,B
1	-13	AN365-832A	4	A,B
1	-14	AN365-1032A	6	A,B
1	-15	AN500A4-6	4	A,B
1	-16	AN507-10R14	6	A,B
1	-17	AN935-6	8	A,B
1	-18	AN935-10	8	A,B
1	-19	AN960-4L	4	A,B
1	-20	AN960-6L	8	A,B
1	-21	AN960-8L	8	A,B
1	-22	AN960-10	8	A,B
1	-23	AN960-10L	14	A,B
1	-24	AN970-3	4	A
1	-25	ANL60	2	A,B
1	-26	ANL130	1	A,B
1**	-27	M6106/19-014	4	A,B
1	-28	MS20470AD4-7	8	A



Z12-036 COMPONENT MAINTENANCE MANUAL

FIG-ITEM	PART NUMBER	NOMENCLATURE	QTY	USAGE CODE	
1	-29	MS35206-229	SCREW	8	A,B
1	-30	MS35206-248	SCREW	4	A,B
1	-31	MS24171-D2	RELAY, (K1, K3, K5, K6) ALT: 6041H202	4	A,B
1	-32	MS24693S52	SCREW	4	A,B
1	-33	MS35207-264	SCREW	8	A,B
1	-34	1N4007	DIODE	12	A,B
1	-35	MDL-1	FUSE (F6, F7, F10)	3	A,B
1	-36	MDL-3	FUSE (F8)	1	A,B
1	-37	MDL-6	FUSE (F4)	1	A,B
1	-38	MDL-15	FUSE (F5)	1	A,B
1	-39	4164	FUSE BLOCK	3	A,B
1	-40	6A10	DIODE	2	A,B
1	-41	Z12-310-1	PLATE ASSY	1	B

** When ordering replacement parts specify K2, K4, K7, K8



Z12-036 COMPONENT MAINTENANCE MANUAL

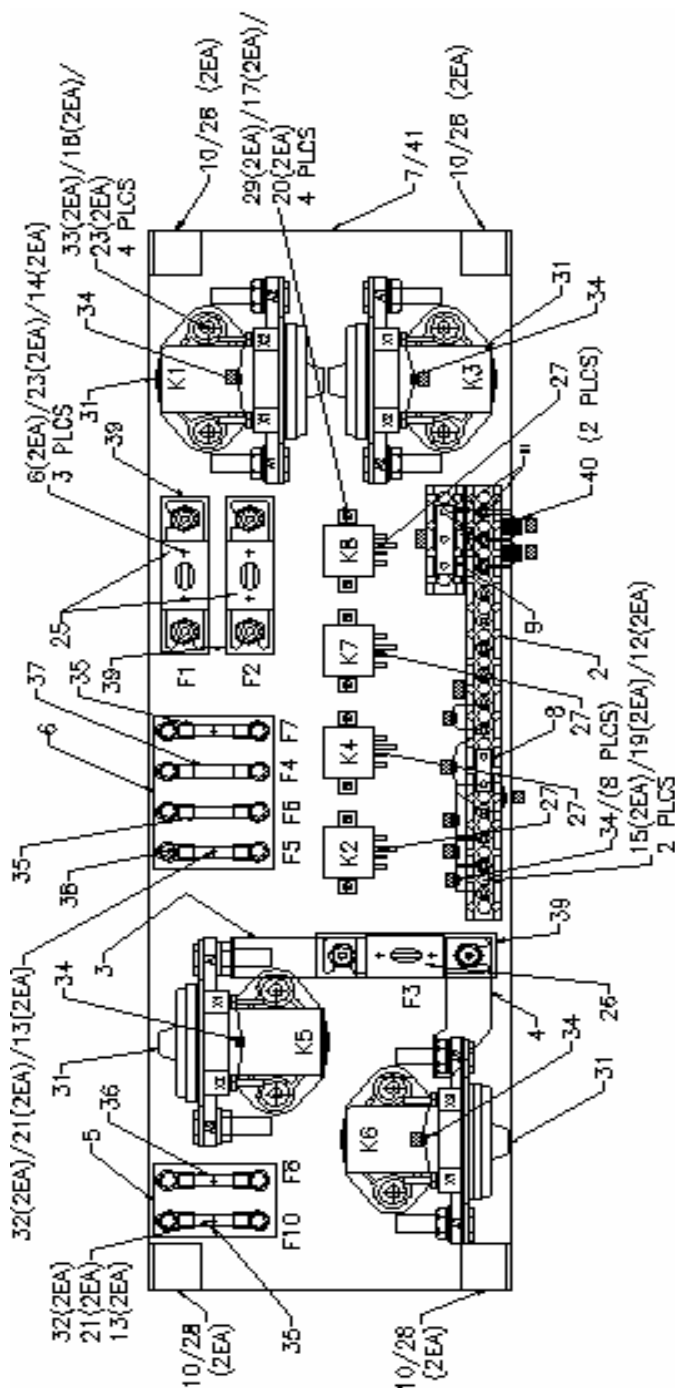

FIG. 1



Z12-036 COMPONENT MAINTENANCE MANUAL

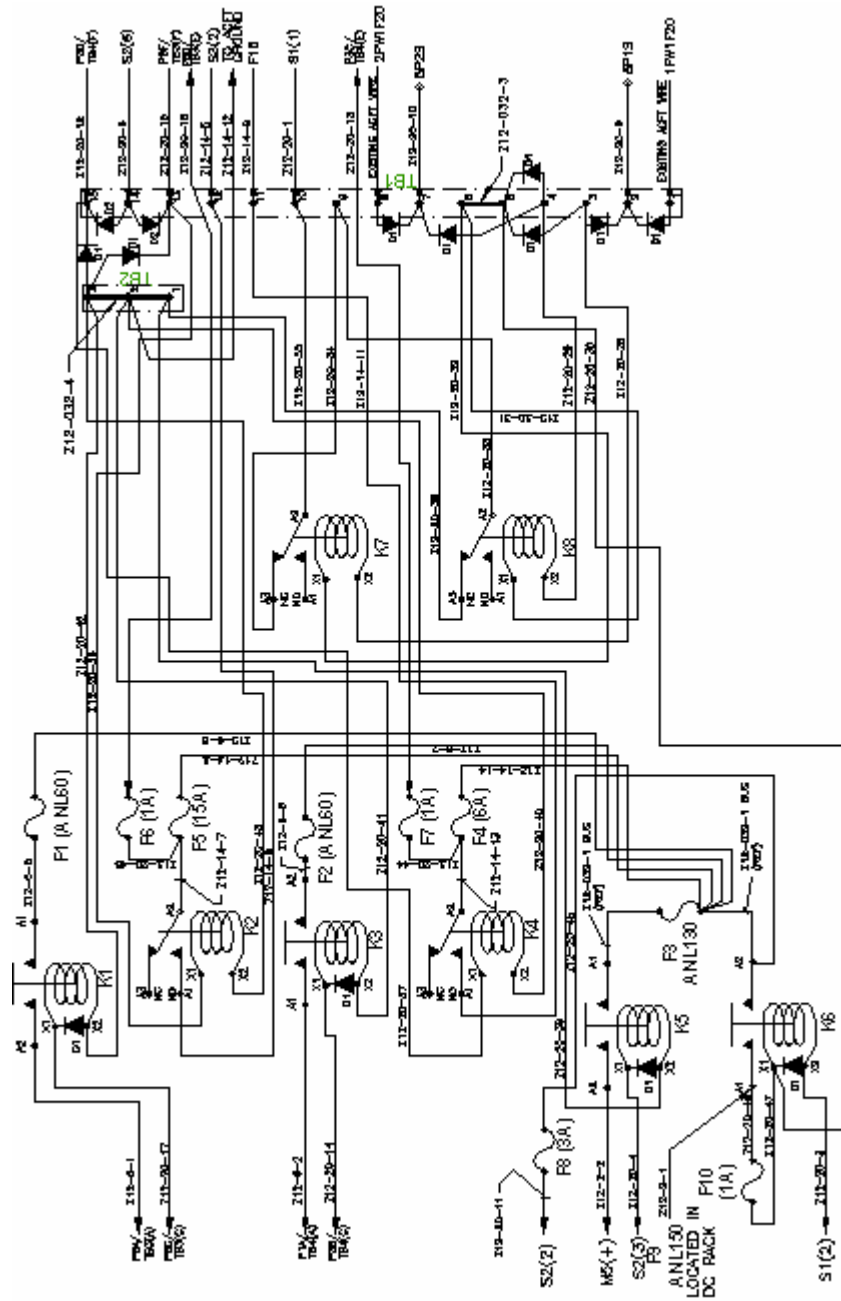

FIG. 2