



**ZEE SYSTEMS, Inc.**  
AIRCRAFT AIR CONDITIONING and  
HEATING SYSTEMS

**Z12-702 COMPONENT MAINTENANCE MANUAL**

***Component  
Maintenance  
Manual***

*with*

*Illustrated Parts List*

*for*

***Z12-702-SERIES***

***Evaporator Assembly***



**ZEE SYSTEMS, Inc.**

AIRCRAFT AIR CONDITIONING and  
HEATING SYSTEMS

## Z12-702 COMPONENT MAINTENANCE MANUAL

### *Record of Revision*

<i>REVISION NO:</i>	<i>ISSUE DATE</i>	<i>POSTED DATE</i>	<i>INSERTED BY:</i>



## **Z12-702 COMPONENT MAINTENANCE MANUAL**

### **List of Effective Pages and Table of Contents**

<b>PAGE</b>	<b>TITLE</b>	<b>EFFECTIVE DATE / REV</b>
1	COVER PAGE	*
2	RECORD OF REVISIONS	*
3	LIST OF EFFECTIVE PAGES	*
4	1.0 INTRODUCTION	*
	2.0 SPECIAL TOOLS AND EQUIPMENT	
5	3.0 REPAIR AND REPLACEMENT OF COMPONENTS	*
	3.1 AIR FILTER	
	3.2 DRAIN LINE	
6	3.3 BLOWER MOTOR	*
	3.4 THERMOSTATIC EXPANSION VALVE	
7	4.0 SERVICING	*
8	5.0 SERVICE SCHEDULES	*
	6.0 TOLERANCES	*
	7.0 TROUBLE SHOOTING	
9	continued	*
10	continued	*
11	8.0 ILLUSTRATED PARTS LIST	*
12	FIGURE 1	*
13	FIGURE 2	*
14	FIGURE 3	*

\* INITIAL RELEASE 10-24-01



## **Z12-702 COMPONENT MAINTENANCE MANUAL**

### **1.0 INTRODUCTION**

1.1 This Component Maintenance Manual provides information on the maintenance, maintenance schedules and repair and replacement of parts.

1.2 Refer to the Illustrated Parts List (IPL) in Section 8 when using this manual or ordering replacement parts. Parts are identified in parenthesis (FIG-ITEM NO.).

1.3 The Z12-702 Evaporator-Heater Assembly was designed utilizing dual axial mounted electrical motor and blower configuration. The squirrel cage blower wheel draws air across the coils and into the aircraft ducting for circulation.

#### **WARNING**

**THIS SYSTEM IS UNDER PRESSURE. INJURY COULD OCCUR IF PROPER SAFETY PRECAUTIONS ARE NOT TAKEN. THE SYSTEM PRESSURE MUST BE RELIEVED BEFORE ANY LINES ARE DISCONNECTED.**

#### **WARNING**

**AVOID PROLONGED SKIN CONTACT WITH THE REFRIGERANT HFC-134a. AVOID CONTACT WITH EYES. DO NOT BREATHE THE FUMES. REFER TO THE MATERIAL SAFETY DATA SHEET FOR INFORMATION ON TREATMENT.**

### **2.0 SPECIAL TOOLS AND MATERIALS**

2.1 No special tools are required to perform the maintenance described in this manual. If the refrigerant has been removed for service, repair or replacement of components refer to ZEE Systems, Inc. CMM Z12-8900 for instruction and special tools to service the system with refrigerant.

2.2 The following equipment and material may be required to perform maintenance in this manual.

ITEM	SOURCE
Liquid Detergent, water soluble	Commercially available
Cloth, lint free	Commercially available
Tape, Insulation,	Commercially available
Detector, Leak, Suitable for HFC-134a	Commercially available



## **Z12-702 COMPONENT MAINTENANCE MANUAL**

### **3.0 INSPECTION, REPAIR AND REPLACEMENT OF COMPONENTS**

3.0.1 Refer to Addison Express Installation drawings for instructions to access the evaporator. Remove the covers/panels as necessary.

3.0.2 The only component on the Evaporator Unit which requires routine maintenance is the inlet Air Filter. The unit and other components are serviced on condition.

#### **CAUTION**

**AIR CONDITIONING SYSTEM UNDER PRESSURE. APPROPRIATE SAFETY MEASURES SHOULD BE TAKEN WHEN SERVICING THIS EQUIPMENT. ONLY TRAINED PERSONNEL WITH APPROVED SAFETY EQUIPMENT SHOULD PERFORM SERVICING DUTIES.**

#### **NOTE**

**IT IS UNLAWFUL TO RELEASE R-12 OR OTHER REFRIGERANTS TO THE ATMOSPHERE. USE APPROVED RECOVERY/RECYCLE EQUIPMENT TO CAPTURE REFRIGERANTS. USE ONLY LAWFUL MEANS TO DISPOSE OF RECOVERED REFRIGERANTS. CHECK WITH LOCAL AGENCIES FOR APPROVED DISPOSAL PROCEDURES.**

#### **NOTE**

**CAP ALL OPEN LINES TO PREVENT CONTAMINANTS AND MOISTURE FROM ENTERING THE SYSTEM.**

#### **NOTE**

**DUE TO THE TIGHT FIT OF THE MOTOR COMPRESSOR CONDENSER ASSY IT MAY BE NECESSARY TO REMOVE THE MOTOR COMPRESSOR CONDENSER ASSY AND THE EVAPORATOR TO PERFORM SOME OF THE MAINTENANCE DESCRIBED BELOW.**

### **3.1 AIR FILTER (1-5)**

3.1.1 **INSPECTION:** Inspect the filter every 100 hours for clogging due to dust or other airborne contaminants. Check for tears in the element. Check the foam insulation for wear or deterioration.

3.1.2 **REMOVAL:** Slide the top of the filter from the housing until it clears the top cover then lift the filter from the evaporator.

3.1.3 **SERVICE:** On condition. Clean the filter with a solution of water and liquid detergent, rinse with clear water. Dry the filter with light compressed air. Care should be taken not to damage the element. Replace foam insulation if worn or damaged.

3.1.4 **INSTALLATION:** Slide the filter into the housing in reverse order of removal.

### **3.2 DRAIN LINE (NOT SHOWN)**



## **Z12-702 COMPONENT MAINTENANCE MANUAL**

3.2.1 INSPECTION: Check that the connection on the external drain tube is secure. Check for any leaks or damaged areas on the flexible tube. Using an Air Supply, apply 10 PSI (max.) to the flexible tube at the highest point to the external drain outlet. Check that drain line is clear.

3.2.2 REMOVAL: Loosen the clamp that attaches the drain line to the evaporator drain pan. And pull the flexible drain line off of the evaporator drain pan tube.

3.2.3 SERVICE: Clear any obstructions as required. Replace flexible tube as required by condition.

3.2.4 INSTALLATION: Slide the flexible tube over the evaporator drain pan tube. And tighten the clamp.

### **3.3 BLOWER MOTOR (2-2)**

3.3.1 INSPECTION: On condition. Check for slow or noisy operation.

3.3.2 REMOVAL: It may be necessary to remove the whole Evaporator Unit from the aircraft. Refer to Addison Express installation drawings for removal procedure. Unsolder the motor red wire at the resistor (3-25) on the blower housing. Remove the three screws and washers (2-21, 2-14, 2-13) and spacers (2-14) between the motor and the blower housing. Disconnect the black ground from the ground post.

3.3.2.1 Note the spacing of the squirrel cage blower wheel on the motor shaft. Loosen the set screw on the squirrel cage and remove from the defective motor and attach squirrel cage blower wheel to the new motor with the same alignment spacing.

3.3.3 SERVICE: There is no field repair for this sealed motor. Replace if defective.

3.3.4 INSTALLATION: Attach the squirrel cage blower wheel on the new motor shaft. Care should be taken to insure the squirrel cage has the same alignment to the motor and is free to rotate. Tighten the set screw. Attach the blower motor with blower wheel to the blower housing in reverse order as removed. Place shrink tube material over the wires that were unsoldered. Solder the red motor wire to the resistor on the same side as the orange wire. Move shrink tubing in place and heat. Connect the black motor wire to the ground post.

### **3.4 THERMOSTATIC EXPANSION VALVE (TXV) (2/3-1)**

#### **CAUTION**

**AIR CONDITIONING SYSTEM UNDER PRESSURE. APPROPRIATE SAFETY MEASURES SHOULD BE TAKEN WHEN SERVICING THIS EQUIPMENT. ONLY TRAINED PERSONNEL WITH APPROVED SAFETY EQUIPMENT SHOULD PERFORM SERVICING DUTIES.**

#### **WARNING**

**SYSTEM IS UNDER PRESSURE AND MUST BE RELIEVED BEFORE ANY SERVICE TO THE EXPANSION VALVE CAN BE ACCOMPLISHED.**

3.4.1 INSPECTION: On condition.



## **Z12-702 COMPONENT MAINTENANCE MANUAL**

3.4.2 REMOVAL: Expose the Thermostatic Bulb on the Suction Line on the evaporator by removing the insulating tape (3-28). Care should be taken not to puncture or damage the bulb or any of the coils on the evaporator. Next, carefully remove the clip (3-27) holding the bulb to the Suction Line, retain it for reinstallation.

3.4.2.1 Disconnect and remove the Inlet Hose (NS). Plug the hose end to prevent any contamination of the system. Hold the expansion valve (2/3-1) with a wrench and loosen the B-Nut on the Pressure Line (Inlet) on the evaporator. Remove the Expansion Valve (2/3-1) including the bulb. Plug the Pressure Line to prevent contamination to the system.

3.4.2.2 Pull the Line Screen (NS) from the expansion valve (2/3-1). Check for any signs of clogging. Clean and remove any foreign matter from the screen.

3.4.3 SERVICE: The only service is to clean the Line screen. Defective expansion valve must be replaced.

3.4.4 INSTALLATION: Connect the expansion valve to the Pressure Line on the evaporator. Use Backup Wrench. Next use clip (3-27) to attach the Thermostatic Bulb to the Suction Line on the evaporator. The Thermostatic Bulb must have FULL contact with the line. Thoroughly cover the bulb by wrapping with insulating tape (3-28).

3.4.4.1 Make sure the line screen (NS) is installed in the expansion valve (2/3-1). Attach the inlet hose to the expansion valve. During servicing check for leaks.

### **4.0 SERVICING – REFRIGERANT CHARGE**

#### **CAUTION**

**AIR CONDITIONING SYSTEM UNDER PRESSURE. APPROPRIATE SAFETY MEASURES SHOULD BE TAKEN WHEN SERVICING THIS EQUIPMENT. ONLY TRAINED PERSONNEL WITH APPROVED SAFETY EQUIPMENT SHOULD PERFORM SERVICING DUTIES.**

#### **NOTE**

**IT IS UNLAWFUL TO RELEASE R-12 OR OTHER REFRIGERANTS TO THE ATMOSPHERE. USE APPROVED RECOVERY/RECYCLE EQUIPMENT TO CAPTURE REFRIGERANTS. USE ONLY LAWFUL MEANS TO DISPOSE OF RECOVERED REFRIGERANTS. CHECK WITH LOCAL AGENCIES FOR APPROVED DISPOSAL PROCEDURES.**

#### **NOTE**

**CAP ALL OPEN LINES TO PREVENT CONTAMINANTS AND MOISTURE FROM ENTERING THE SYSTEM.**

4.1 CHECK THE SYSTEM. Anytime refrigerant has been lost or removed from the system. Check for leaks and secure all plumbing connections before filling the system with refrigerant. Refer to ZEE Systems, Inc. CMM Z12-8900 for required equipment and materials to service the air conditioning system.



**Z12-702 COMPONENT MAINTENANCE MANUAL**

**5.0 SERVICE SCHEDULES**

**5.1 MAINTENANCE SCHEDULE**

ITEM DESCRIPTION	INSPECTION INTERVAL *	R&R/T.B.O. HRS
SZ84-010-3 Air Filter	Every 100 Hrs. Inspect for tears or damage. Refer to 3.1.	ON CONDITION
ITEM DESCRIPTION	INSPECTION INTERVAL *	R&R/T.B.O. HRS
SZ63-021-1 Blower Motor	N/A	ON CONDITION
BFJB-CP60 TXV	N/A	ON CONDITION

**6.0 TOLERANCES**

6.1 TORQUE VALUES. Use standard torque values for bolts and other fasteners.

**7.0 TROUBLE SHOOTING**

TROUBLE	POSSIBLE CAUSE	REMEDY
Evaporator Blowers low flow	Obstructed blower Inlet.	Remove obstruction.
	Obstructed duct.	Remove obstruction.
	Obstructed Outlet.	Remove obstruction.
Evaporator Blowers Inoperative.	Motor open. Motor brushes worn beyond limits.	Replace Motor Blower Assy.
	Check fuse on fuse block	Replace fuse
	Check wiring to motor. Check switch in cockpit. Check motor for shorts.	Repair or replace faulty system or component.





## **Z12-702 COMPONENT MAINTENANCE MANUAL**

<b>TROUBLE</b>	<b>POSSIBLE CAUSE</b>	<b>REMEDY</b>
System not cooling with. Adequate airflow over evaporators	Condenser airflow blocked.	Remove obstruction.
	Low refrigerant.	Service system.
	Overcharge of refrigerant.	Service system
	Faulty Compressor	Replace Compressor.
	High Discharge Pressure Overcharge of refrigerant.	Service system
	Obstruction in Receiver-Dryer.	Replace defective component and service system
	Obstructed Expansion Valve and/or Line Screen.	Clean Line Screen. Replace Expansion Valve and service system
Low Discharge Pressure.	Low refrigerant.	Service system
	Faulty Compressor.	Replace bad component and service system
Excessive vibration at Motor/Compressor.	Improper belt tension.	Adjust belt to correct tension.
	Worn, damaged or loose or over tightened mounts.	Adjust or replace mounts.
Quick refrigerant loss.	Open in system.	Check compressor head gasket. Check Hoses or tubing for holes. Check connections. Replace defective component. Service system
Defective O-Ring.	Replace defective O-Ring. Service system	



**ZEE SYSTEMS, Inc.**  
AIRCRAFT AIR CONDITIONING and  
HEATING SYSTEMS

## **Z12-702 COMPONENT MAINTENANCE MANUAL**

<b>TROUBLE</b>	<b>POSSIBLE CAUSE</b>	<b>REMEDY</b>
	Loose connections.	Tighten connections. Service system
Slow refrigerant loss.	Loose connections.	Tighten connections. Service system



**Z12-702 COMPONENT MAINTENANCE MANUAL**

**8.0 ILLUSTRATED PARTS LIST**

**8.1 EXPLANATION OF SYMBOLS:**

ALT - The Part Number shown is an approved alternate, either part number may be used.

MOD "X" Refers to modification information of this part as applicable to this assembly.

NP - Not Procurable individually, see next higher assembly.

NS - Not Shown

OBS - Obsolete

USAGE/QTY - This identifies parts used on specific applications (not common to all units).

.. - Part of higher assembly.

\*/# - See explanation at end of parts list.

<b>FIG-ITEM</b>	<b>PART NUMBER</b>	<b>NOMENCLATURE</b>	<b>QTY</b>	<b>USAGE</b>	
	Z12-702-1	EVAPORATOR ASSEMBLY		A	
	Z12-702-2	EVAPORATOR ASSEMBLY		B	
2/3	-1	BFJB-CP60	EXPANSION VALVE	1	
2	-2	SZ63-021-1	MOTOR	2	
3	-3	SZ63-023-1	BLOWER MOTOR ASSY	2	
1/3	-4	SZ84-009-11	COVER	1	
1	-5	SZ84-010-3	FILTER, AIR	1	
3	-6	Z12-033-5	FUSE HOLDER	1	
1	-7	Z12-037-1	SHUNT	1	
1/3	-8	Z12-304-2	DRAIN PAN	1	
2/3	-9	Z12-306-6	HOUSING	1	A
		Z12-306-5	HOUSING	1	B
1/3	-10	SZ-85-005-1	COIL ASSY	1	
	NS	SZ63-326CCW-5/16	BLOWER WHEEL	2	
3	-11	AN935-6	WASHER, LOCK ALT: MS35338-41	4	
1/2	-12	AN935-8	WASHER, LOCK ALT: MS35338-42	12	A
		AN935-8	WASHER, LOCK ALT: MS35338-42	21	B
1/2	-13	AN960-8L	WASJER, FLAT ALT: NAS1149FN816P	12	A
		AN960-8L	WASJER, FLAT ALT: NAS1149FN816P	21	B
2	-14	AN960-10	WASHER, FLAT ALT: NAS1149F036P	12	
1	-15	MDL-4	FUSE	2	
1/3	-16	MDL-6	FUSE	2	
NS	-17	MS3367-4-9	TIE WRAP	AR	
	-18	NOT USED			
1	-19	MS35206-228	SCREW	2	
1/2	-20	MS35206-245	SCREW	12	A
		MS35206-245	SCREW	20	B
2	-21	MS35206-246	SCREW	6	
3	-22	MS35265-29	SCREW	4	
3	-23	MS35335-31	WASHER, STAR EXTERNAL	2	
3	-24	N3	CLAMP, NYLON	2	



**ZEE SYSTEMS, Inc.**

**AIRCRAFT AIR CONDITIONING and  
HEATING SYSTEMS**

## **Z12-702 COMPONENT MAINTENANCE MANUAL**

<b>FIG-ITEM</b>	<b>PART NUMBER</b>	<b>NOMENCLATURE</b>	<b>QTY</b>	<b>USAGE</b>
3 -25	RH-50	RESISTOR	2	
NS -26	02150800	THREADCERT	4	
3 -27	14-2388	CLIP	1	
3 -28	18-2710	INSULATION	AR	
2/3 -29	2606	ADAPTER ALT: 920-2606	1	
NS -30	2609	ADAPTER ALT: 920-2609	1	
NS -31	406772-1	I.D. PLATE	1	
4 -32	67470	INSULATION	AR	



**Z12-702 COMPONENT MAINTENANCE MANUAL**

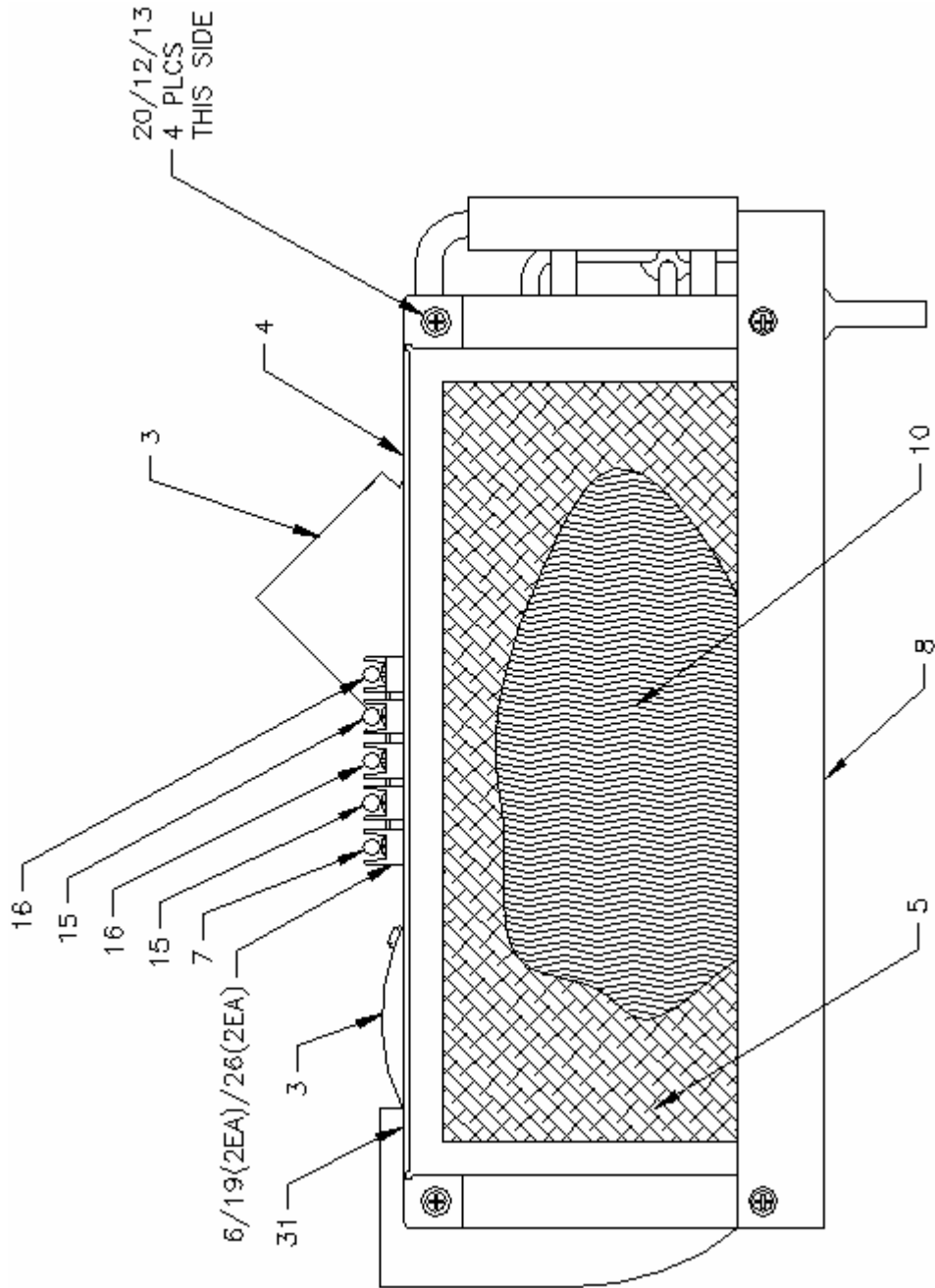

**FIG. 1**



**Z12-702 COMPONENT MAINTENANCE MANUAL**

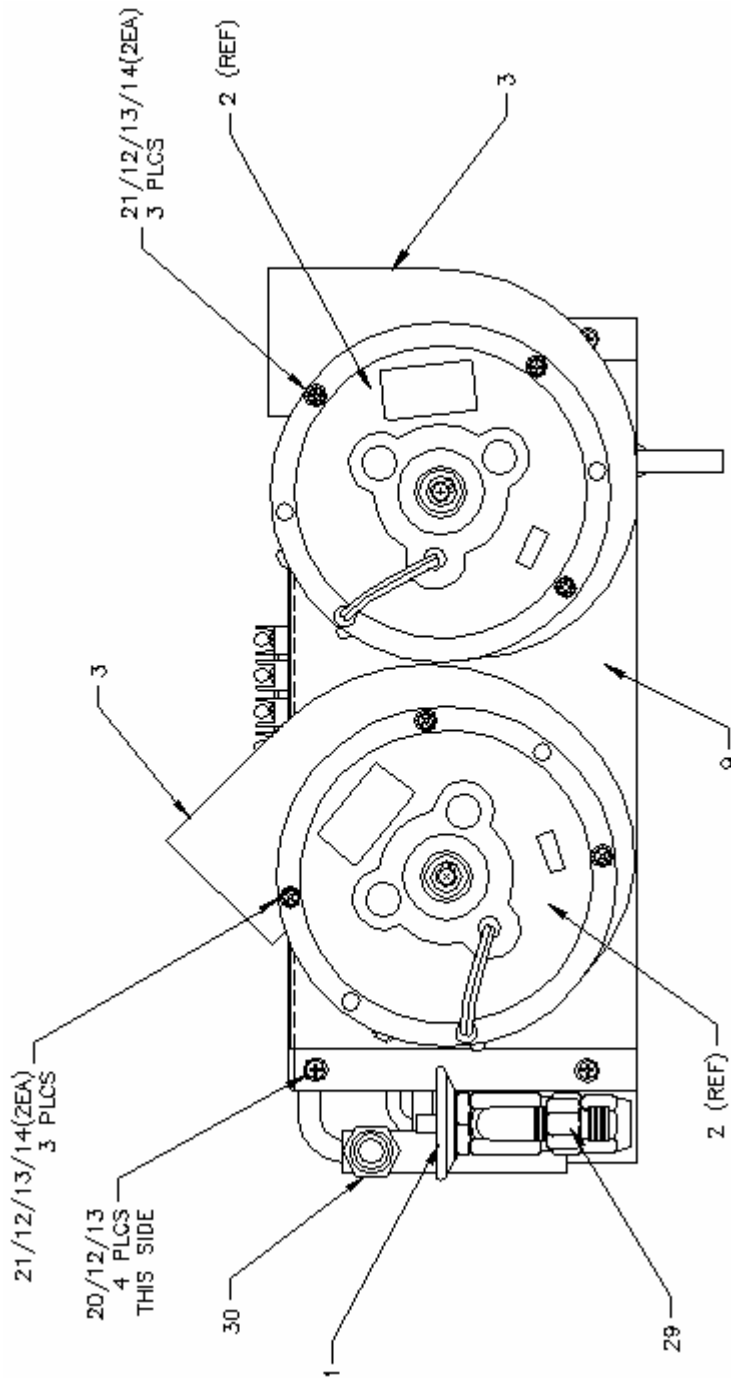

**FIG. 2**



**Z12-702 COMPONENT MAINTENANCE MANUAL**

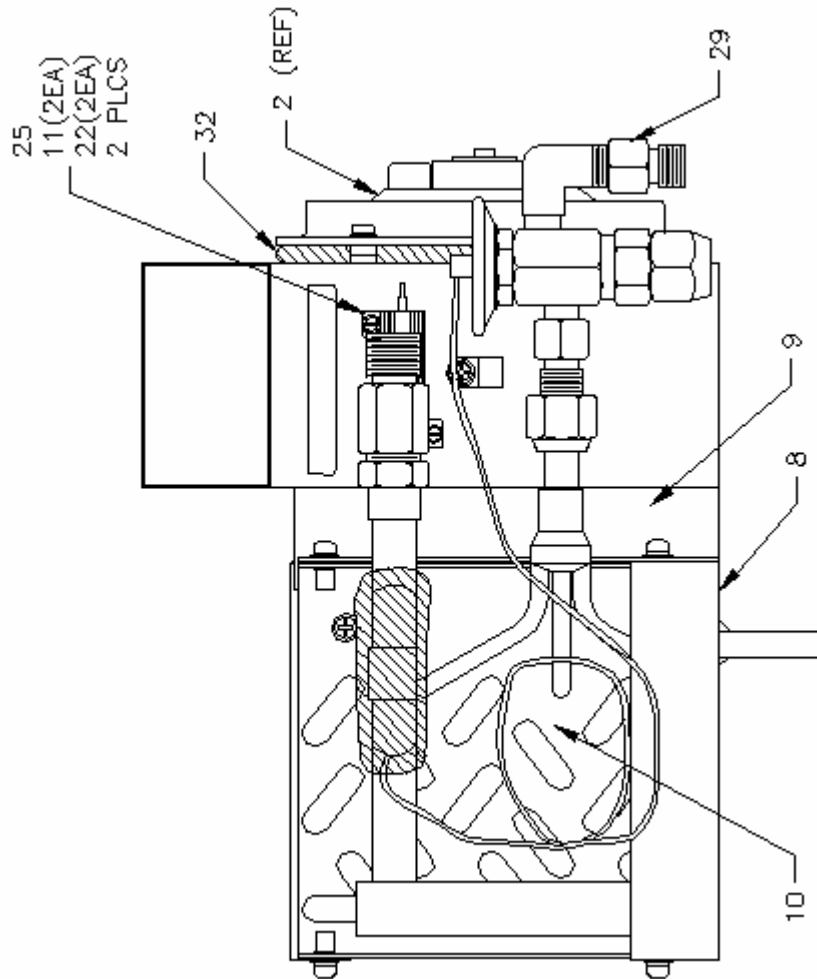

**FIG. 3**