



ZEE Systems, Inc.

SERVICE BULLETIN 83-001-2

1.0 EFFECTIVITY: ZEE Systems, Inc. P/N SZ83-001-1B Motor Compressor Condenser Assembly (MCC) installed as part of STC SA1734GL

2.0 PURPOSE: To modify the MCC to use R-134a refrigerant.

2.1 Description of MOD D: This service bulletin gives instructions for modifying the SZ83-001-1B Motor Compressor Condenser Assembly to be assembled with the latest Z26-8900 MC and SZ83-040 PC configuration without the oil recovery components. Assemblies manufactured after December 1997 will use E.P.A. accepted R-134a as the standard refrigerant. Assemblies manufactured after September 2006 will have MOD D incorporated during manufacture. This modification supersedes MOD A and MOD B and MOD C. This service bulletin should be accomplished at the same time as SB 78-001-1 and SB R134-06.

2.2 New Installation: Install equipment as normal R-12 system. Refer to Service Bulletin R134-06 for additional modification instructions to allow the use R-134a refrigerant for equipment installed under STC SA1734GL.

2.3 Modification of existing system: This conversion consists of removing some components and replacing some components.

3.0 COMPLIANCE: Compliance is optional.

4.0 APPROVALS: This service bulletin contains no modification data that changes the fit, form or function of the original design and therefore does not require any additional approvals. There are no changes to the operating characteristics of the air conditioning equipment. There is no part number change.

5.0 WEIGHT AND BALANCE: MCC Unit becomes approximately 7 lbs lighter.

6.0 ELECTRICAL LOAD DATA: No change.

7.0 SPECIAL TOOLS AND EQUIPMENT: Equipment used in Discharging and Charging the system.

Refrigerant Recovery/Recycle Equipment meeting SAE J1990 or J2209 specifications.	Commercially Available
Manifold Gauge Set, with hoses R-134a compatible	Commercially Available
Scale .1 lb. increments	Commercially Available
Leak Detector	Commercially Available
Vacuum Pump	Commercially Available
Temperature Measuring Device	Commercially Available
R-134a (HFC-134a) Refrigerant	Commercially Available
Sanden SP-20 or PAG-100 Oil	Commercially Available



ZEE Systems, Inc.

SERVICE BULLETIN 83-001-2

8.0 MANPOWER REQUIREMENTS:

8.1 New Installation: When incorporating this service bulletin during new manufacture no additional man hours are required over the normal installation time.

8.2 Modification of existing system: No man hour estimates are available at this time. This upgrade will require the MCC Assembly P/N: SZ83-001-1B be returned to ZEE Systems, Inc. for modification.

9.0 INSTRUCTIONS: The MCC must be removed from the aircraft and returned to ZEE Systems, Inc. for modification. Refer to STC information for instructions to remove the unit from the aircraft.

CAUTION

SYSTEM UNDER PRESSURE. APPROPRIATE SAFETY MEASURES SHOULD BE TAKE WHEN SERVICING THIS EQUIPMENT. ONLY TRAINED PERSONNEL WITH SAFETY EQUIPMENT SHOULD PERFORM THESE DUTIES.

NOTE

IT IS UNLAWFUL TO RELEASE R-12 TO THE ATMOSPHERE. USE APPROVED RECOVERY/RECYCLE EQUIPMENT TO CAPTURE THE R-12. USE ONLY LAWFUL MEANS TO DISPOSE OF RECOVERED R-12. CHECK WITH LOCAL AGENCIES FOR APPROVED DISPOSAL PROCEDURES.

NOTE

CAP ALL LINES TO PREVENT CONTAMINANTS AND MOISTURE FROM ENTERING THE SYSTEM.

NOTE

USE A BACKUP WRENCH WHEN LOOSENING OR TIGHTENING FITTINGS. DO NOT OVER TIGHTEN.

9.1 Recover the refrigerant from the system.

9.2 Disconnect and remove the MCC from the aircraft.

9.3 Modify the MCC in accordance with ZEE Systems, Inc. E.O. 83-001-3.

9.4 Install the modified MCC into the aircraft. Add 3 oz. of PAG-100 oil to the condenser coil prior to installation.

9.5 Service the system in accordance with ZEE Systems, Inc. Service Letter R134-06.

10.0 TESTING: Test the modified MCC in accordance with E.O. 83-001-3.

10.1 Prior to initial system start up and every 25 HRS for the first 200 HRS of operation check the oil level in the compressor. Close the back seat valves prior to removing the oil fill plug. Service the compressor with oil as necessary. Open the back seat valves prior to operating the system. Refer to CMM SZ83-001-1B.



ZEE Systems, Inc.

SERVICE BULLETIN 83-001-2

NOTE

PAG OIL ABSORBS MOISTURE VERY QUICKLY. NEVER LEAVE THE SYSTEM OR OIL CONTAINER EXPOSED TO AIR FOR PROLONGED TIME. TIGHTLY RESEAL THE OIL CONTAINER AND SYSTEM AFTER EXPOSING THE OIL TO AIR. ANYTIME THE SYSTEM HAS BEEN OPENED EVACUATE AT A DEEP VACUUM FOR AT LEAST 1 (ONE) HOUR.

10.2 The only field testing that may be required is to check for leaks. Before the MCC is reinstalled in the aircraft cap the condensing coil outlet (bottom No. 6 tube) and cap the suction fitting (No. 10 bulkhead fitting on the gusset). Connect a refrigerant bottle to the charging gauge manifold. Connect the manifold to the high and low service connections. Open the back seat valves on the compressor. Introduce a static charge of refrigerant to the MCC. Check for leaks with a R-134 leak detector. Before disconnecting the service connections close the back seat valves on the compressor.

10.3 Electrical operation of the MCC may be tested prior to system start up.

10.3.1 To check the SZ58-003 Motor and SZ65-800 Power Condenser Fan, attach main power wires to the Motor on the MCC. Apply power, the motor and fan should start and run normally.

10.3.2 To check to compressor clutch you will need to by pass the Z99-032 High/Low Pressure Switch. Remove COIL (+) wire from C post on the terminal block. Apply 28 VDC to COIL (+) wire with any ground. The clutch should pull in with an audible click. After test return wire COIL (+) to C post of the terminal block.

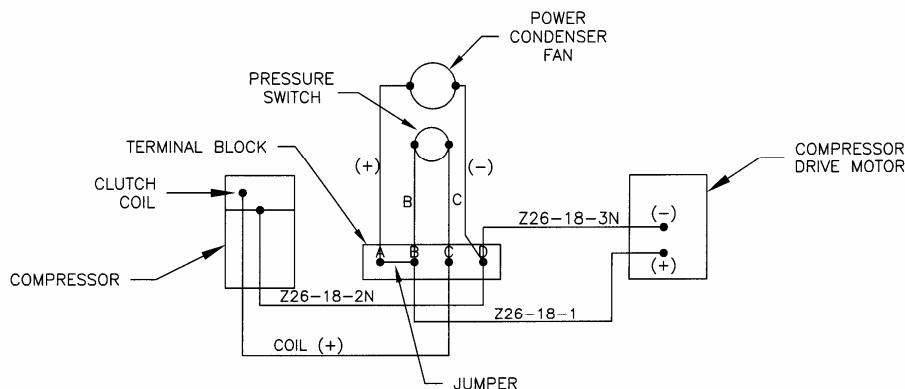

WIRING DIAGRAM 1.

CAUTION

DO NOT CHECK THE CLUTCH OPERATION BY APPLYING POWER DIRECTLY TO POST C ON THE TERMINAL BLOCK. DAMAGE TO WIRING MAY OCCUR AS A BACK FEED MAY TRY TO ENERGIZE THE COMPRESSOR DRIVE MOTOR.



ZEE Systems, Inc.

SERVICE BULLETIN 83-001-2

11.0 MAINTENANCE SCHEDULES:

- | | |
|--|--|
| EVERY 25 HRS for the
First 200 HRS of operation | Check oil level in the compressor. |
| EVERY 100 HRS | Check oil level in the compressor. |
| EVERY 500 HRS | Check brushes in the SZ58-003-1 Motor
Check Belt for wear and proper tension. |
| EVERY 1500 HRS | Overhaul SZ58-003-1 Motor. |

14.0 REFERENCE MATERIAL: Refer to CMM SZ83-001-1B, Motor Compressor Condenser Assembly for basic service instructions. Refer to Service Bulletin R134-06 for R-134a servicing instructions. Refer to ZEE Systems, Inc. E.O. 83-001-3. For online publications go to www.zeeeco-zeesys.com.

15.0 MATERIAL COST AND AVAILABILITY: Contact ZEE Systems, Inc. for pricing and availability. Cost will vary with the condition of the MCC to be modified.

**ZEE SYSTEM, Inc.
406 W. Rhapsody
San Antonio, TX 78216**

**TEL: 800-988-COOL₍₂₆₆₅₎ or 210-342-9761
FAX: 210-341-2609
e-mail: info@zeeeco-zeesys.com
www.zeeeco-zeesys.com**