



**ZEE Systems, Inc.**

***SERVICE LETTER 47-003-4***

- 1.0 EFFECTIVITY: All SZ47-003-(X) Blower Assemblies.
- 2.0 PURPOSE: To provide an alternate kit for the replacement of the Blower Motor in the Blower Assembly.
- 3.0 COMPLIANCE: Compliance is optional.
- 4.0 APPROVALS: This Service Letter allows an alternate motor support for the Blower Assembly. No additional approvals are required. Replacement parts are FAA-PMA where the SZ47-003-(X) Blower is eligible.
- 5.0 WEIGHT AND BALANCE: No change from original configuration.
- 6.0 ELECTRICAL LOAD OR PERFORMANCE DATA: No change.
- 7.0 SPECIAL TOOLS: None.
- 8.0 MAN POWER REQUIREMENTS: 1.0 man hours to remove the defective motor and wheel and install the new motor and wheel in the blower housing. This estimate does not include removal from the aircraft and reinstallation and documentation.
- 9.0 INSTRUCTIONS:
- 9.1 Remove the 8 Trac screws that hold the two blower housings together. Retain the screws for reassembly. Remove the Top Housing (17-2641). Note the spacing of the Blower Wheel in the Lower Housing (17-2642). Note that one of the screw heads has been machined down. Install in the same location, See FIG. 3.
- 9.2 Remove the motor to be replaced. Note the spacing of the Blower Wheel on the shaft.
- 9.3 If a dual shaft SZ7411FB Motor is ordered you must determine the desired rotation and then cut off the opposite shaft. Refer to SL47-003-1 for instructions. After the shaft has been cut see Section 12.0 for marking instructions.
- 9.4 After the opposite shaft has been removed place 1 each Motor Support SZ47-302-1 on each end of the motor. Secure as shown on parts break down, see FIG. 1.
- 9.5 The 16-2527 Blower Wheel rotation must match the rotation of the shaft. See FIG. 2. Push the Blower Wheel onto the shaft until you have the same spacing as the old wheel. Fit the motor and wheel into the Lower Housing (17-2642). Adjust the position of the wheel on the shaft so it does not touch the housing on either side. Adjust the spacing of the wheel on the shaft as necessary. When the proper spacing is achieved attach the 916-901 Clip on the Blower Wheel.



ZEE Systems, Inc.

**SERVICE LETTER 47-003-4**

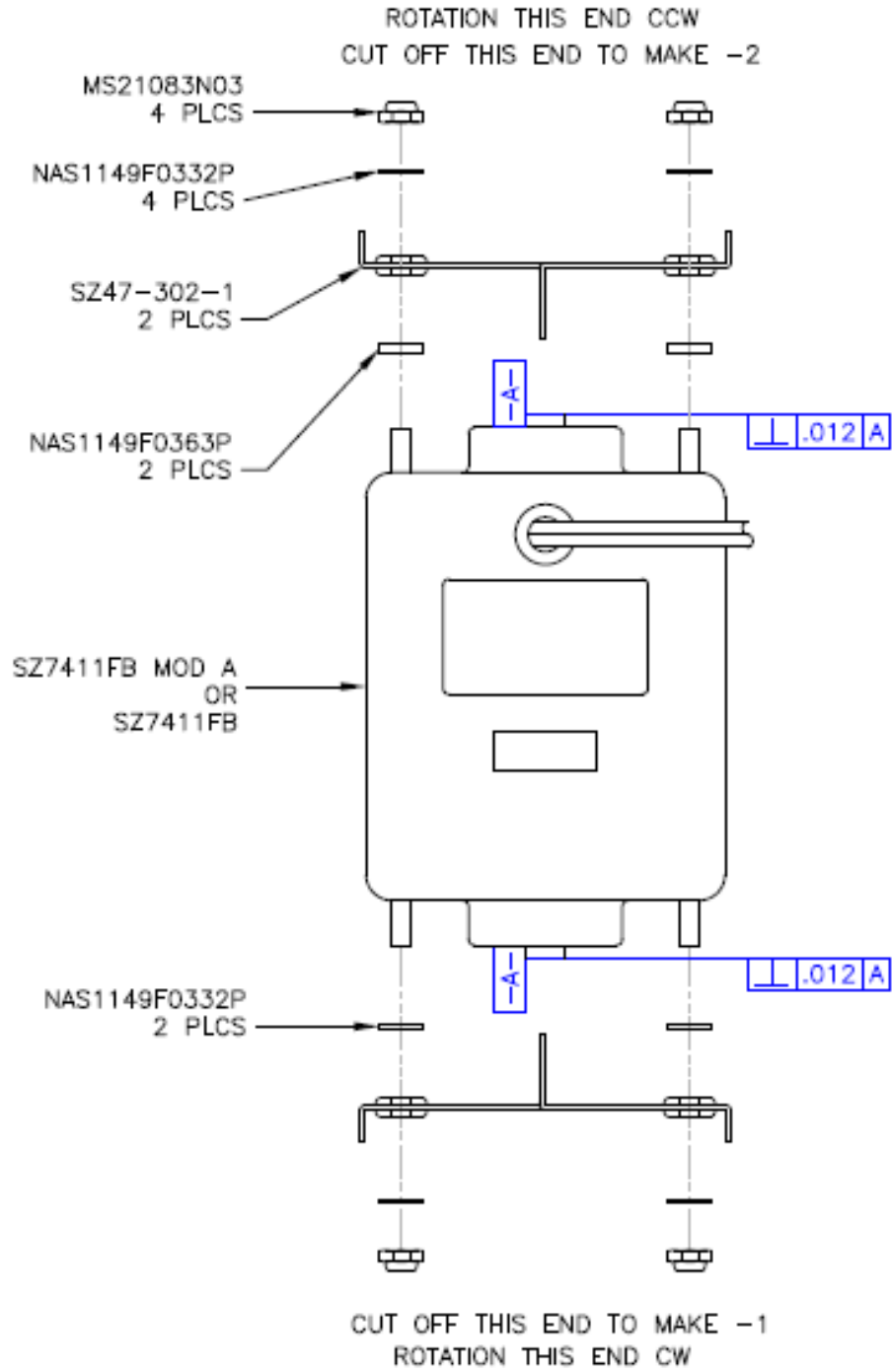
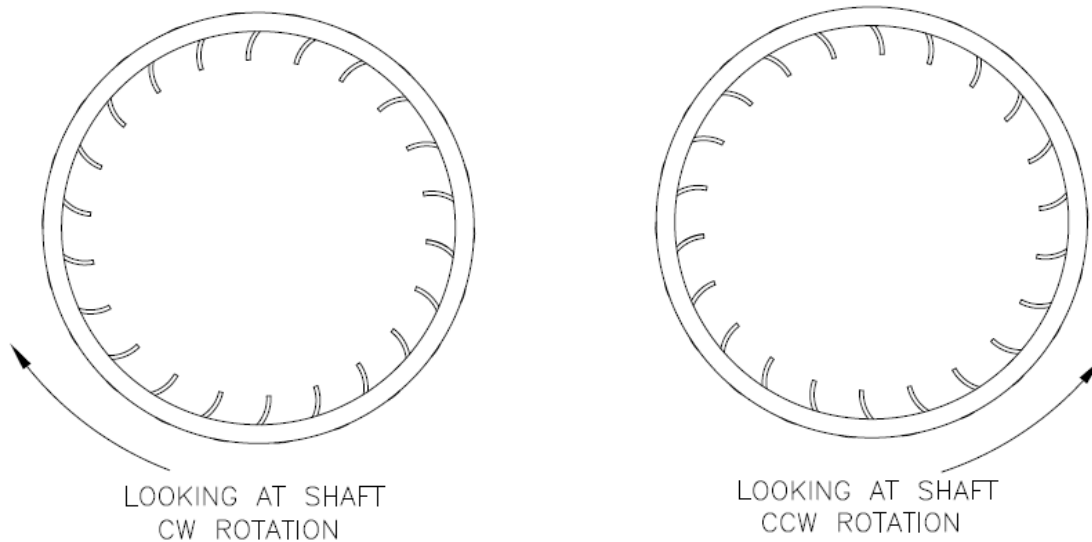

FIG. 1



**ZEE Systems, Inc.**

**SERVICE LETTER 47-003-4**



**FIG. 2**

9.6 Place the 17-2641 Top Housing on the 17-2642 Lower Housing and secure with the 8 each 8 x 5/8 Trac screws.

10.0 REFERENCE MATERIAL: For downloadable documents visit:

[www.zeeco-zeesys.com/Zee\\_Systems\\_Publications.htm](http://www.zeeco-zeesys.com/Zee_Systems_Publications.htm)

SL47-003-1

SL47-003K

SIL47-003B

11.0 TESTING: To test apply 28 VDC to the Blower Assembly. Run at each of the speeds. Check for binding, excessive noise, excessive current draw.

SZ7411FB (MOD A)

Black – Ground	CURRENT
Red – Low	2.3A ± .5A
Yellow – Medium	3.3A ± .5A
Orange – High	5.5A ± .75A

SZ7411FB

Black – Ground	CURRENT
Red – Low	3.25A ± .5A
Yellow – Medium	4.5A ± .5A
Orange – High	8.0A ± .75A



**ZEE Systems, Inc.**

***SERVICE LETTER 47-003-4***

12.0 IDENTIFICATION: After the shaft has been cut to the proper rotation, on the motor I. D. Plate at the end of the part number mark as follows:

Motors with a clock-wise (CW) rotation mark **-2**.

Motors with CCW counter clock-wise (CCW) rotation mark **-1**.

13.0 RECORDS: Complete appropriate documents as required by governing civil aviation authority. Mark a 'C' at the end of the serial number on the I.D. Plate. This indicates that SL 47-003-4 has been accomplished.

14.0 MATERIAL COST and AVAILABILITY: Order Kit P/N: SZ47K003-4. Kit contains the following parts:

1ea SZ7411FB (MOD A) Motor or Alternate SZ7411FB

2ea SZ47-302-1 Supports

1ea 16-2527 Blower Wheel

1ea 916-901 Clip

4ea MS21083N03 Nut, Lock

6ea NAS1149F0332P Washer, Flat, Thin

2ea NAS1149F0363P Washer, Flat, Thick

For Price and Delivery contact:

ZEE Systems, Inc.

T 800-988-2665 x202

T 210-342-9761 x202

F 210-341-2609

info@zeeco-zeesys.com

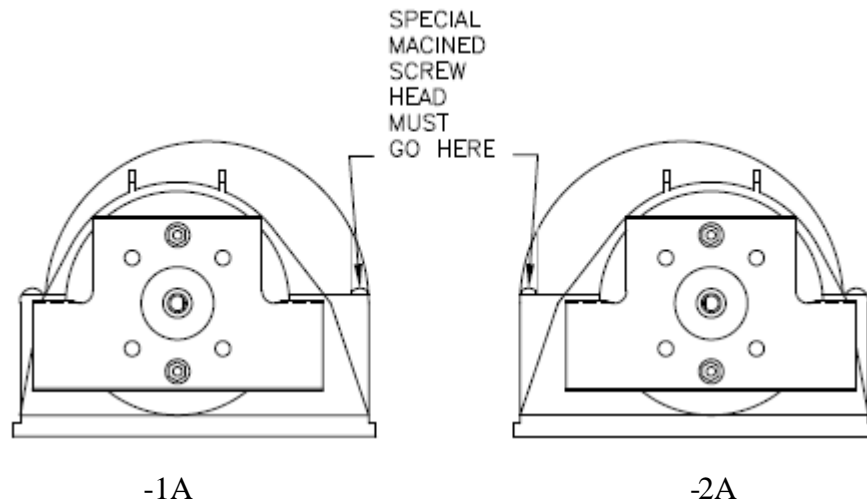

FIG. 3